

WPCT156.001

Wöhr Projected Capacitive

Touch Panel Product Specification

15,6 INCH PROJECTED CAPACITIVE TOUCH PANEL

Our information does not release the customer from the obligation to check the suitability for the intended application area in each case. We reserve the right to make technical changes at any time without prior notice. We shall not assume any liability in connection with application technology consulting. The issue of this form is not registered and thus not subject to change control. Therefore, always check whether you have the latest version. (Version: 07.12.2012)

Table of contents

1. General description	3
1.1. Overview	3
1.2. Features	3
1.3. General specifications	3
1.4. Touch Panel Specification	4
2. Reliability test report and specifications	4
2.1. Mechanical characteristics	4
2.2. Reliability specifications	5
3. Appearance and cosmetic inspection	6
3.1. Inspection environment conditions	6
3.2. Cosmetic specifications	7
4. Precautions	9

1. General description

1.1. Overview

It is a Projected Capacitive Touch Panel with USB interface to support and compatible with WIN7 O/S system for multi-touch application.

1.2. Features

ITMES	SPECIFICATIONS
Panel Size	15,6 inch
Structures	Glass/Glass (ITO glass with Chemical enhanced)
Total Thickness	2.4 ± 0.15 mm (Cover_1.1 mm & Sensor_1.1 mm)
Operation Conditions	-10°C ~ +60°C at Min 20% to Max 90% RH
Storage Conditions	-15°C ~ +65°C at Min 10% to Max 90% RH
ElectroStatic Discharge (Non-Operation)	Contact : ±4KV, 3times/1point, 1time/1sec, Total 3points. Air : ±8KV, 3times/1point, 1time/1sec, Total 3points.

Note 1 : In order to make a touch panel operate normally, please make sure that the host device is grounded.

Note 2 : All environmental characteristics listed as above all should be less than 1 atmosphere.

Note 3 : The touch panel must be assembled with LCD panel by VHB or other materials, the control board also be fixed on LCM bezel or other mechanical parts of the system and then be grounded; In ESD test, the function and appearance should be available when electrostatic charge. It is acceptable that the display flicker when electrostatic discharge.

Note 4 : The touch panel may be damaged functionally or unstable if the panel does not be grounded through your system to earth.

Note 5 : In order to make a touch panel operate normally, power supply or power adapter have to conform to IEC 62684.

1.3. General specifications

ITMES	SPECIFICATIONS	NOTE
Input Method	Finger or Cap. Stylus	
Accuracy	Within 2.5mm each target & 10% Jitter limit on moving	Based on WIN7 definition ppi (Pixel per inch)
Resolution	25ppi (Min.)	
Transparency	90 ± 2%	By BYK-Gardner at 550nm.
Haze	3% (Maximum)	

Note 1 : The optical characteristics listed as above are measured by BYK-Gardner instrument at 550nm wavelength.

1.4. Touch Panel Specification

See Drawing

Note 1 : All of the corners and edges of the glass that have chamfer process by CNC machines and all dimensions and tolerances will be defined on the drawing of the touch panel.

2. Reliability test report and specifications

2.1. Mechanical characteristics

ITEMS		CONDITIONS	PASS CRITERIA
Panel	Ball drop test	227g ± 2g 40cm	No damage at each cycle drop 5points and each point drop 1 time only.
	Hardness	Pencil : 7H Pressure : 1N/45°	Hardness ≥ 7H
	Warpage	By Cage	Warpage ≤ Length * 0.1%
FPC/COF Reliability	Direction of peeling off	90°	Strength ≥ 500gf/cm
	Speed of Pulling out	50mm/min	

Note 1 : The ball drop test illustration is showed as follow.

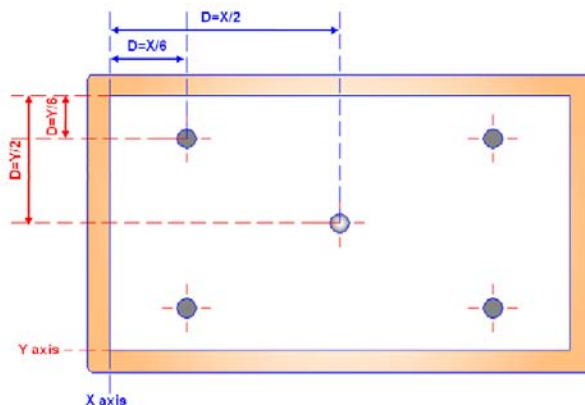

Note 2 : The hardness test follows up to JIS K-5400 serials industry standard and the test illustration is showed as below.

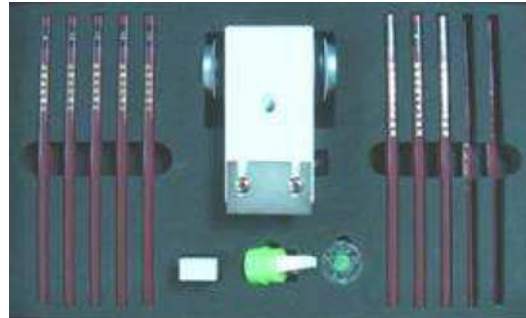

Note 3 : The FPC/COF peeling strength test illustration is shown as below, and the test method follows the standard as ASTM D903 / ASTM D3807.

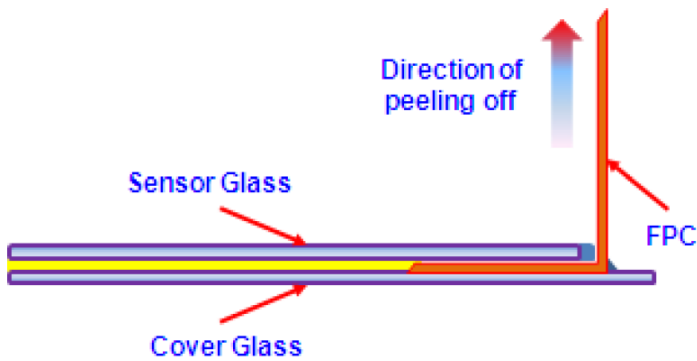

2.2. Reliability specifications

Environment test conditions are listed as follows.

ITEMS	SPECIFICATIONS
Temperature Cycling	The product should be allowed to stand at 0°C to +60° C with 90% RH for 240hrs un-load condition and allowed to be normalized for 4hrs.
Thermal Shock	The product should be allowed to stand at -40°C to +85°C for 30min/cycle with totally 50cycles and allowed to be normalized for 4hrs.
High Temp. Storage	The sample should be allowed to stand at +85°C for 240hrs un-load condition and allowed to be normalized for 4hrs.
Low Temp. Storage	The sample should be allowed to stand at -40°C for 240hrs un-load condition and allowed to be normalized for 4hrs.

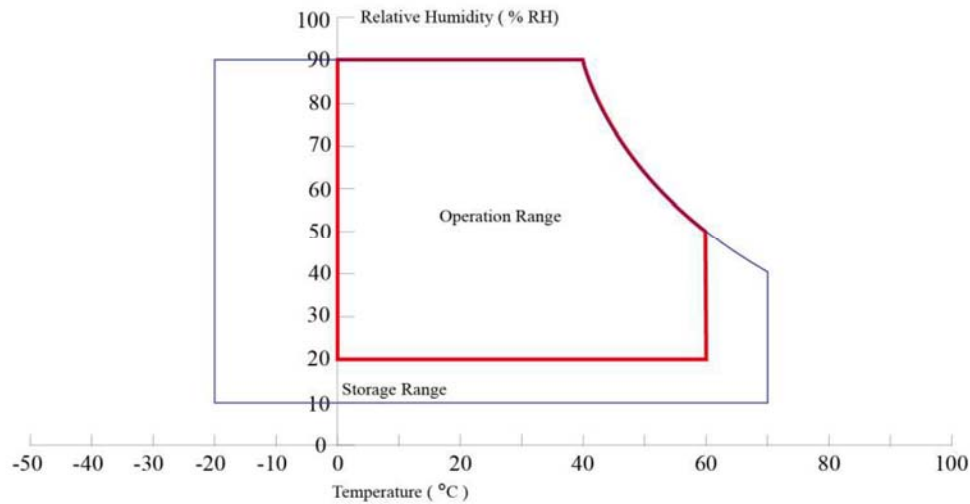

3. Appearance and cosmetic inspection

3.1. Inspection environment conditions

- 1) The touch panel has to be inspected at a clean room of at least class 10,000.
- 2) The visual inspection environment should be set at 15 to 25 degree C and 25% to 75% humidity.
- 3) The illumination of the appearance inspection should be 800~1000Lux with fluorescent reflection light source.
- 4) The visual inspection should be kept the distance 35cm or more between the touch panel and the raw eyes of inspectors.
- 5) The viewing angle should be 45 ± 10 degree with an inspectors raw eyes when visual inspection.
- 6) Visual inspection time is 25 ± 5 second per ones that we are recommended.
- 7) The dirty defect should be judged with the 25% of contrast film in the point rule.
- 8) The visual inspection illustration is showed as below.

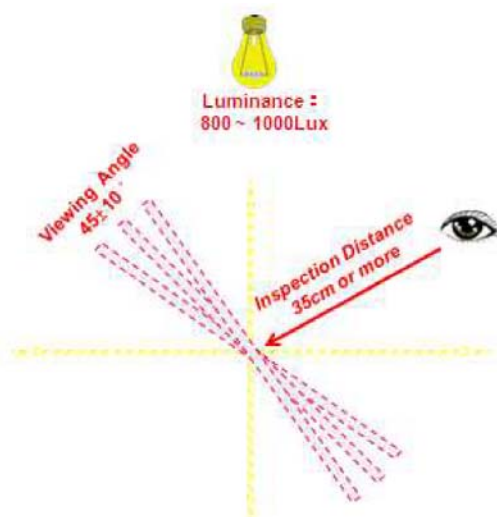

3.2. Cosmetic specifications

Defects are classified two types, one is major and the other is minor according to the defect specification, and they were definition as follows.

Test method : According to ANSI/ASQC C1.4-2003. General Inspection Level II take a single time.

- 1) Major defect
- 2) Any defect may result in functional fail or reduce the usability such as electrical failure, deformation etc.
- 3) Minor defect
- 4) It doesn't reduce the usability such as line defect, dot defect etc.
- 5) The defects classify of AQL as following:
 Major defect : AQL=0.65. Minor defect : AQL=2.5. Total defects : AQL=2.5.

Cosmetic defect definition and specifications

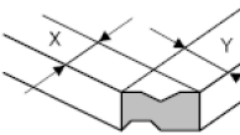
COSMETIC DEFECT DEFENITION		SPECIFICATIONS	PASS CRITERIA
Linear Defects (Scratch/Scrub/ Fiber/Particle)	Scratch/Scrub	$W \leq 0.05\text{mm}$	Ignore
		$0.05\text{mm} < W \leq 0.2\text{mm}$ and $L \leq 15\text{mm}$	$N \leq 5$
		$W > 0.2\text{mm}$ or $L > 15\text{mm}$	Not Allowed
	Fiber/Particle	$W \leq 0.1\text{mm}$	Ignore
		$0.1\text{mm} < W \leq 0.3\text{mm}$ and $L \leq 10\text{mm}$	$N \leq 5$ and Distance $\geq 5\text{mm}$
		$W > 0.3\text{mm}$ or $L > 10\text{mm}$	Not Allowed
Dot Defects (Bubble/Fiber/ Particle/Spot/Dent/ Nick)	Active Area	$D \leq 0.1\text{mm}$	Ignore
		$0.2\text{mm} < D \leq 0.4\text{mm}$	$N \leq 5$ and Pitch $\geq 5\text{mm}$
		$D > 0.4\text{mm}$	Not Allowed
	Printing Area	$D \leq 0.2\text{mm}$	Ignore
		$0.2\text{mm} < D \leq 0.4\text{mm}$	$N \leq 4$ Pitch $\geq 5\text{mm}$
		$D > 0.4\text{mm}$	Not Allowed
Printing Defects	Pine Hole	$D \leq 0.3\text{mm}$, $N \leq 4$, Pitch $\geq 2\text{mm}$	Ignore
		Peak to Peak $\leq 0.2\text{mm}$	Border Area Acceptable
	Light Leakage	Peak to Peak $\leq 0.1\text{mm}$	Logo/icon Area Acceptable
Breakage Defects	Corner Defect 	$X \leq 3.0\text{mm}$ & $Y \leq 3.0\text{mm}$ If $Z \leq T/2\text{mm}$	Be Allowed on Cover Glass
		$X \leq 3.0\text{mm}$ & $Y \leq 3.0\text{mm}$ If $Z \leq T/2\text{mm}$	Be Allowed on Sensor Glass
	Edge Defect	$X \leq 3.0\text{mm}$ & $Y \leq 3.0\text{mm}$ If $Z \leq T/2\text{mm}$	$N \leq 3$ /Edges Distance $\geq 20\text{mm}$

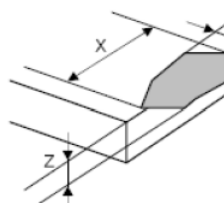
			Be Allowed on Cover Glass
		$X \leq 3.0\text{mm}$ & $Y \leq 3.0\text{mm}$ If $Z \leq T/2\text{mm}$	$N \leq 3/\text{Edges}$ Distance $\geq 10\text{mm}$ Be Allowed on Sensor Glass
ID Appearance		All dimensions by procedures via mechanical must be followed by customer's drawing definition.	All dimensions and tolerances must be followed by customer's drawing definition.
Color Shift		Be followed by customer's AI drawing and "PANTONE" no. definition	Be followed by "PANTONE" no. or checked by golden sample if have argued.
IR Hole Printing		all of the marks	Be followed by customer spec or checked by golden sample

Note 1 : "L" means Length, "W" for Width, "N" for Quantity and "Pitch" for the distance between both defects.

Note 2 : $D=(X+Y)/2$, and dot sharp diagram showed as below.

Note 3 : "L" means Length, "D" for Width, and linear sharp illustration is showed as below.

Note 4 : If the shape of particles is not dot or line,

<A> Put Ruler on the particle and inspect it by the inspection method of the particle.

 Use the inspection method of the linear particle to inspect the particle, if the size of the particle exceeds the range of the dot particle.

Note 5 : The size of the defects should be measured by Ruler.

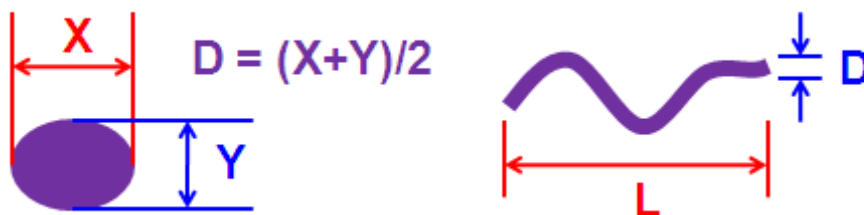

4. Precautions

ITEM	EXPLANATION
Storage	<ul style="list-style-type: none"> • A touch panel should be stored under the environment temperature and humidity controlled as suggested. • Do not store a touch panel in direct sunlight.
Handling	<ul style="list-style-type: none"> • Unpack the carton with the printed red arrow pointing up. • Hold a touch panel body instead of the FPC/COF all the time. • Avoid that the surface of the sensor glass is polluted after removing the protect film when assembly.
Cleaning	<ul style="list-style-type: none"> • Prevent using any kind of the chemical solvent, acidic or alkali solution when cleaning. • Neutral detergent or isopropyl alcohol was suggested if the panel is cleaned.
Assembly	<ul style="list-style-type: none"> • Do not apply rough force such as bending or twisting to the touch panel during assembly. • Excessive force or strain to the panel or FPC/COF is prohibited. • Past VHB tape or sponge with adhesive on the gap between a touch panel and a LCD module to segregate water and dust contamination.
Operation	<ul style="list-style-type: none"> • The panel must be operated in a steady environment, the abrupt change of the environment conditions may cause the malfunction of the panel. • In order to guarantee all functions of a touch panel stable, please make sure that system is grounded or a power adapter is connected correctly to ground loop (Connection to earth ground is suggested). • Do not pull the interface connector in or out while the touch panel is operating. • Any sharp edged or hard objects are interdiction to hitting when touch panel operation.
Others	<ul style="list-style-type: none"> • The product meets the specification requirement of the ROHS standard criteria. • Wöhr GmbH will provide 12 months product guarantee under normal operation conditions. • If the panel will be used in extreme conditions such as high temperature, high humidity, high altitude or long operation time etc., it is strongly recommended to contact Wöhr GmbH for field application engineer's advice. Otherwise, its reliability and function may not be guaranteed. • Avoid high voltage and/or static charge being applied to touch module. • Keep the panel surface clean. Prevent any kind of adhesive applied on the surface. • It is support two fingers touch only and it would be malfunction when over two fingers touch together.



	<ul style="list-style-type: none">• To avoid the metal or any kind of the electric conduction materials on the touch screen when you are handling.• Any kind of the non-electric conductor may cause the malfunction when that applied due to touch screen is sensing by human body.
--	---

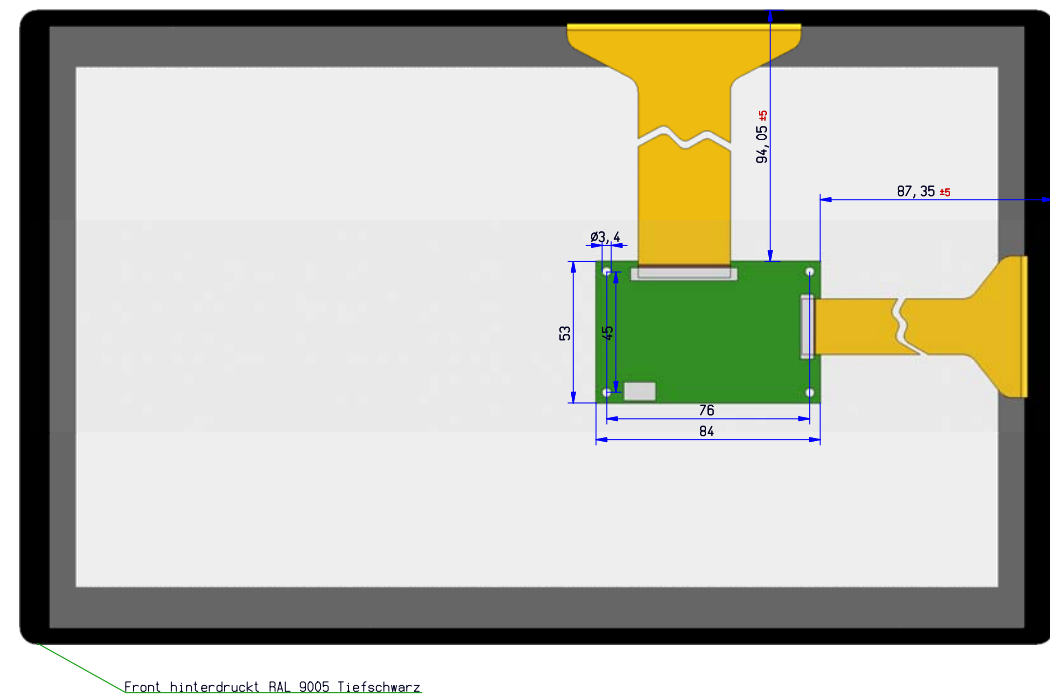
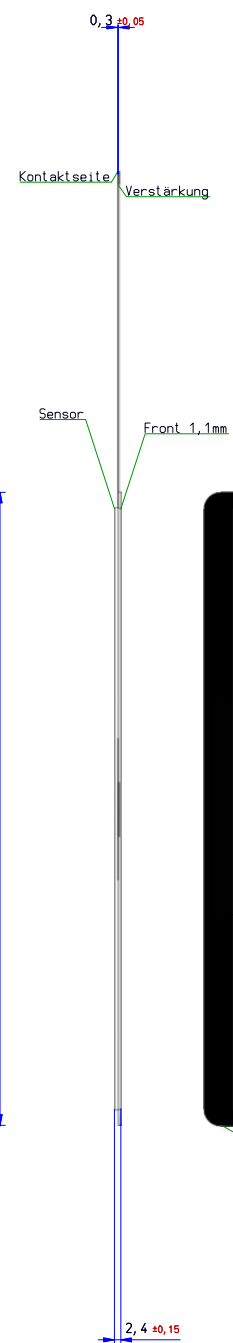
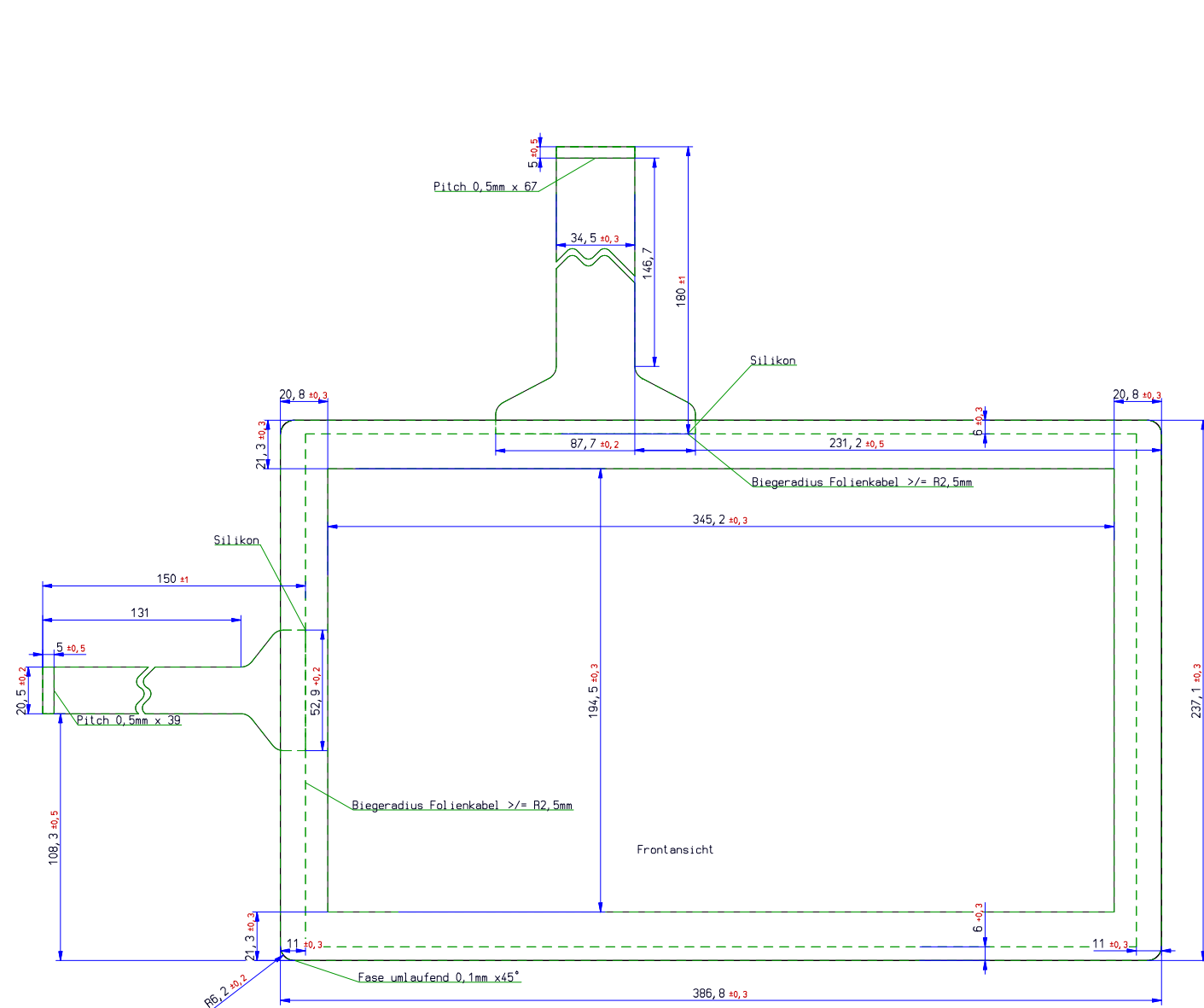

Pinbelegung	Folienkabel 68x0,5
Pin 1	NC
Pin 2	Dummy X
Pin 3 - 48	X46 - X1
Pin 49	Dummy X
Pin 50 - 68	NC

Pinbelegung	Folienkabel 40x0,5
Pin 1 - 11	NC
Pin 12	Dummy Y
Pin 13 - 38	Y1 - Y26
Pin 40	NC

Pinbelegung	USB Anschluß
Pin 1	EGND
Pin 2	VCC
Pin 3	GND
Pin 4	D+
Pin 5	D-

Muster		1:1	Gezeichnet
Schäfer nach DIN 9135 beachten / Freizeichner nach DIN 7560			
Bsp. 13.01.2012 A. Schmalz		B6: WPCT Touch Modul	
Richard Woehr GmbH D-75339 Höfen / Enz Richard@woehr.com		WPCT156_001	
Material:		Blatt 1	
15.1		15.6	